

WE SPECIALIZE IN TURBOCHARGERS.



ALAMO
INDUSTRIES LTD.

24 HOUR SERVICE
REPAIR. SUPPLY. FABRICATION.

ALAMOTURBOCHARGERS.COM

WHAT WE OFFER.

Who We Are	4
Where We Are	5
Our Partners	6
Our Safety	7
Our Facilities	8

ABOUT US

Industrial Turbochargers	12
Performance & Diesel Turbochargers	14
A.I.L.™ Billet & OEM Exhaust Regulators	16
Blowers Charge Air Coolers	18
Engine Parts Exhaust Manifolds	19
Expansion Joints Gasket & Mounting Kits	20
Water Jumpers	21

PRODUCTS

Compressor Component Repair	22
24 Hour Service Exchange Program	24
Factory Overhaul Pick-Up & Delivery	25
Shop Online Quality Control	26
Welding & Machining	27

SERVICES

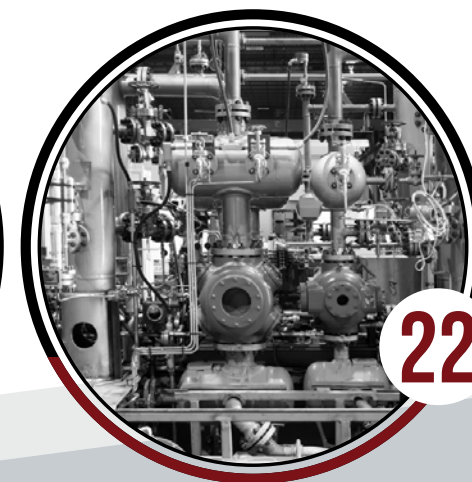
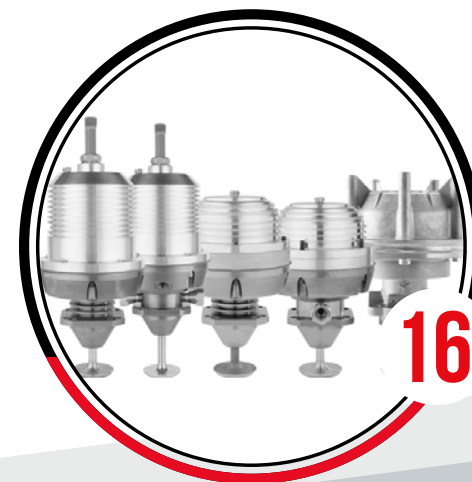
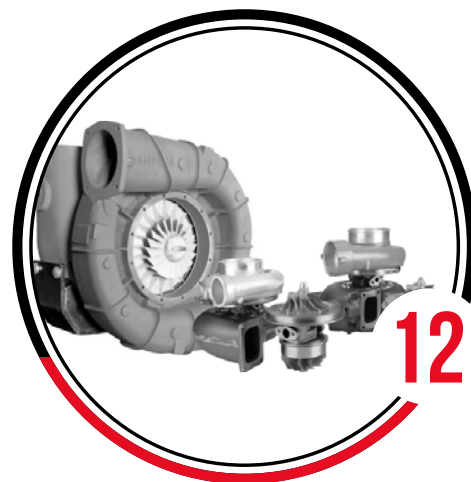

WHO
WE
ARE

Alamo Industries Ltd. is a premium full service turbocharger repair and supply company established in 1978, headquartered in Calgary, Alberta.

We are a privately owned Canadian business, spanning across three locations in North America. Our collective of employees are certified industry professionals, who together embody our mission of a relentless pursuit of excellence.

Our quality control measures allow us to be proactive in finding problems beyond the turbocharger itself, assisting our customers in correcting conditions that could lead to further downtime and expenditures.

We strive to be a direct, reliable, and cost effective point of contact for our customers while continuing to provide an excellent standard of quality. Our turnaround time on repairs and comprehensive exchange program have set the industry standard for service, as we understand that things need to be done quickly and correctly – the first time.

**BEST
TURNAROUND
IN THE INDUSTRY.**

CALGARY, AB

Bay #30
5225 - 6 Street NE
T2K 5Y4

Office: 403-274-6211
Fax: 403-275-4600
Toll Free: 800-988-7260

EDMONTON, AB

16661 - 113 Avenue NW
T5M 2X2

Office: 780-487-6211
Fax: 780-487-6219
Toll Free: 800-988-7260

KENT, WA

22737 - 72 Avenue S.
Building C, #109
98032

Office: 253-872-0662
Fax: 253-872-0664
Toll Free: 800-838-3064

All locations accept walk-ins and offer complimentary visual inspections for light duty models.

All locations are certified distributor centres for BorgWarner, Garrett, Holset, and IHI product.

OPEN

$\frac{8}{AM}$ to $\frac{5}{PM}$

ON CALL

24/7, All Locations

BE SOCIAL



@AlamoIndustriesLtd.
www.alamoturbochargers.com

WHERE
WE
ARE



OUR PARTNERS

• • • •

We are proud to be authorized distributors for BorgWarner, Garrett, Holset, and IHI. As an authorized distributor we receive advantage orders and specialized training on product updates, allowing us to offer our customers the latest technology in the turbocharger industry.

In addition to providing a full range of first-fit OEM product, all three of our facilities are qualified to provide factory overhaul services to genuine product and custom builds when necessary.

BORGWARNER
GARRETT
HOLSET
IHI.

• • • •

At Alamo we are committed to conducting our business in a manner that protects the health and safety of our employees, subcontractors, customers, and the environment. We believe that strong communication is a key component of a successful Health and Safety Program.

In addition to daily toolbox meetings held between management and shop technicians, we employ a full-time Safety Coordinator and conduct monthly safety and committee meetings to ensure that all employees are meeting safety training requirements and consistently working in a safe and healthy manner.

We understand that many of our customers have very specific vendor requirements concerning on-site decorum. In accordance with our safety program, we maintain a detailed safety data management system, which tracks all customer related training and orientation prerequisites.

Our company has a current Certificate of Recognition (COR) through the Manufacturers' Health and Safety Association (MHSA), and we are subscribers to Avetta, ComplyWorks and ISNetworld.



OUR SAFETY

OUR FACILITIES



Bay #30, 5225 - 6th Street NW | Calgary, AB



16661 - 113th Avenue NW | Edmonton, AB



22737 - 72nd Avenue S. - Bldg C, #109 | Kent, WA

At our corporate facility in Calgary we maintain 25,000 square feet of warehouse, manufacturing, and sales space. All of our upgraded premium products are manufactured or finished in-house.

Our Edmonton location specializes in the sale, service, and repair of turbochargers and items related to the oil and gas and diesel industries. Edmonton is stocked with a complete line of product to service our northern Alberta customer base in addition to British Columbia and Saskatchewan.

Our Seattle sister company, Alamo Turbocharger Services Inc., maintains the same standard of work and quality assurance. This 3,800 square foot facility specializes in the sale, service, and repair of small frame turbochargers for transportation, marine, construction, and mining industries.



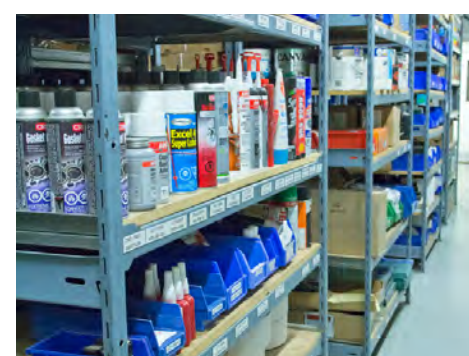

INDUSTRIAL TURBOCHARGERS

At Alamo we stock a large inventory of complete units and all critical parts for the various turbochargers found in the oil and gas, marine, and agricultural industries. In addition to our supply and repair options we also have an extensive exchange program, with all operations performed in-house from teardown, machining, welding, and balancing.

We have designed and manufactured many of the premium upgraded components stocked in our inventory. This ensures a product that is equal to, and in most cases, superior to the O.E.M. product it replaces.

Our philosophy has always been that cost savings to our customers can only come from better products and improved procedures. This is evident in the increased service life of our products, such as our stainless steel nozzle rings, A.I.L.™ billet regulators, and our line of stainless steel exhaust bellows.

In order to address the issue of premature thrust failure, we designed and released an extreme duty upgraded turbocharger for the 3500 Series Caterpillar engine. These units use ball bearing technology and are made of premium grade material manufactured in North America to ensure superior quality. These units are available to replace all TW and UTW9200 series units.

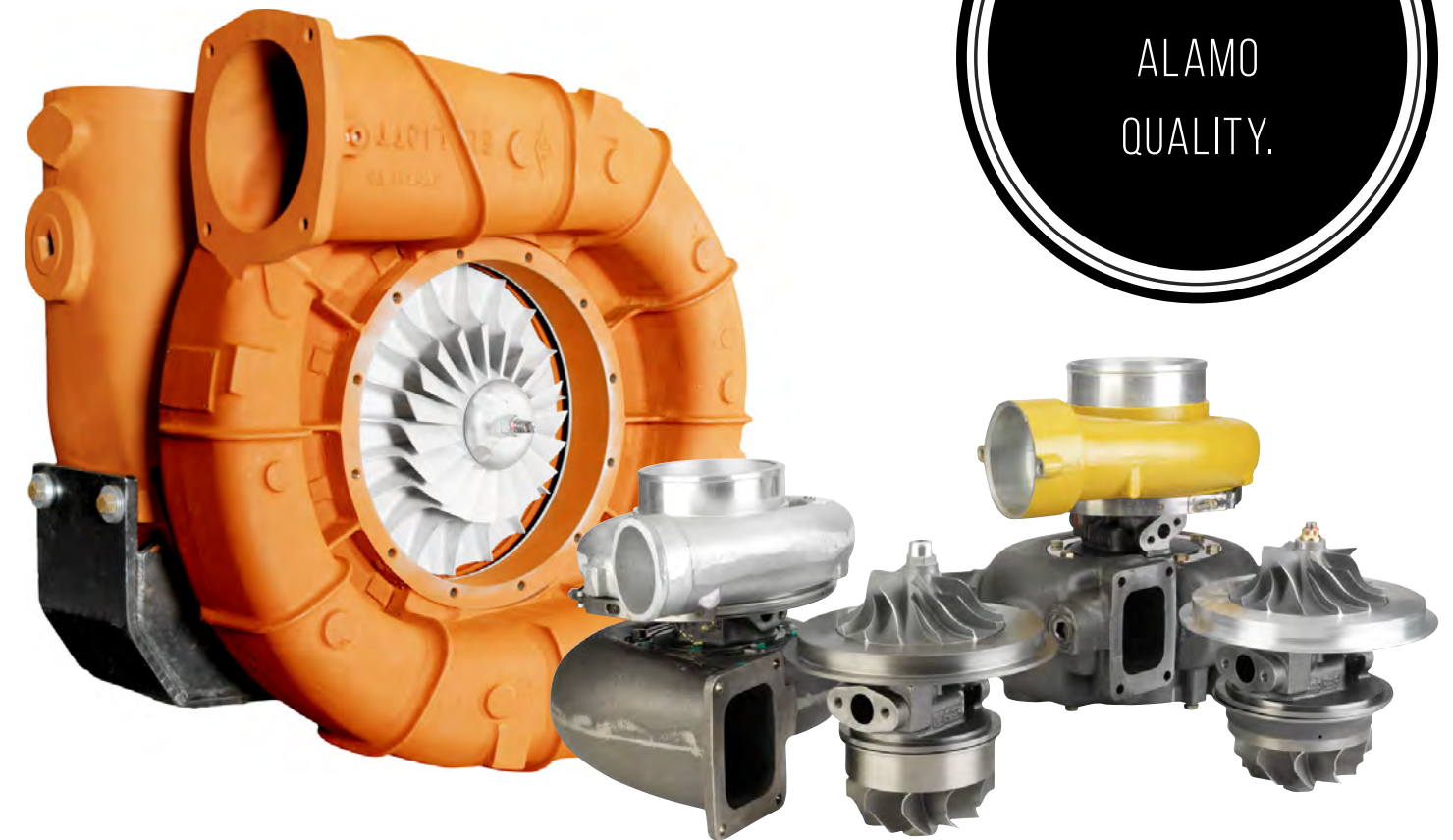

DEMAND
ALAMO
QUALITY.

PREMIUM
SERVICE,
IN-HOUSE.

ABB Asea Brown Boveri® ALCO®	Elliott® EMD®	Napier®
Clark® Cooper Bessemer®	KBB®	PBS®
DeLaval®	MAN®	Not seeing what you're looking for? Call us.

PERFORMANCE & DIESEL TURBOCHARGERS

We are dedicated to supporting high performance culture, as we have been involved in the racing scene in North America since the early 90's through various sponsorships.

An enthusiastic staff heads our performance and diesel division, which manufactures and stocks a wide variety of turbochargers for automotive, diesel, and natural gas applications. With all of our locations being certified distributor centres for BorgWarner, Garrett, Holset, and IHI product our customers can be assured that they are receiving the latest in turbocharger technology and technical support.

Together with our knowledge and certification in the performance sector, we are able to offer a variety of options including *factory overhaul*, *aftermarket sourcing*, *custom design*, *fabrication*, and *troubleshooting*.

At Alamo we understand that not every customer wants a stock configuration, which is why we offer fabrication on any application from light diesel pick-ups to tuner cars. In custom applications ensuring the right match of turbocharger to engine is critical; when you deal with us as turbocharger specialists our research and development ensures that your setup will be engineered for high efficiency and long service life.



AFTERMARKET.
CUSTOM DESIGN.
FABRICATION.

FULL
POWER
RANGE.

GASOLINE	LIGHT DUTY PICKUP	ON-HIGHWAY TRUCK
BorgWarner® EFR, SX, SX-E	Dodge Cummins® 5.9L - 6.7L	Caterpillar® 3406, C15, C16
Garrett® GT Ball Bearing	GM Duramax® 6.6L	Detroit® Series 60
	Ford Power Stroke® 6.0L - 7.3L	Cummins® ISX®

A.I.L.™ BILLET & OEM EXHAUST REGULATORS

Alamo Industries Ltd. has been manufacturing regulators for over a decade. We have an extensive in-house quality control program for every step of the manufacturing and assembly process.

All of the A.I.L.™ brand of regulators are a direct OEM replacement and machined from top quality exhaust grade bar stock, with a multiple bolt pattern that fits a wide variety of applications. All of the regulator parts at Alamo are comprised of billet material, as the added aluminum ribs assist in the dissipation of heat better than any sand casting process.

The “A” series air-cooled base regulator was developed to eliminate the possibility of dangerous coolant leaks that can happen with non-billet regulator bodies. These regulators are internally air cooled and the AIL-99 is fully adjustable from 9” of Hg to 72” of Hg.

The “W” series water-cooled base regulator is available on both the fully adjustable AIL-99 and the non-adjustable AIL-95 regulators.

We stock a full line of OEM exhaust regulators for Caterpillar and Waukesha GSI and GL applications.



**DIRECT
OEM
REPLACEMENT.**

A.I.L.™, ADJUSTABLE 3306 - 7044	A.I.L.™, NON-ADJUSTABLE 379 - 7042	OEM
AIL-99GLA AIL-99GLW	AIL-95GLA AIL-95GLW	Caterpillar® 176746B - 7W5496
AIL-99GSIA AIL-99GSIW AIL-99SV	AIL-95GSIA AIL-95GSIW AIL-95SV	Waukesha® 208372H - 295645S

BLOWERS

Alamo Industries Ltd. has serviced many turbo blowers in our history, including several gear driven Cooper Bessemer units.

In addition to providing in-house repair services, we stock most standard overhaul components.



CHARGE AIR COOLERS

Alamo Industries Ltd. maintains an inventory of the common charge air coolers found in the industry. These units are repaired, remanufactured, and assembled with new gaskets.

All air seams are pressure checked to ensure soundness. We have improved the integrity of the charge air coolers by using higher quality joint washers. Many of our customers report improved engine operation through reduced charge-air temperatures by servicing their coolers at the same time as the turbocharger.

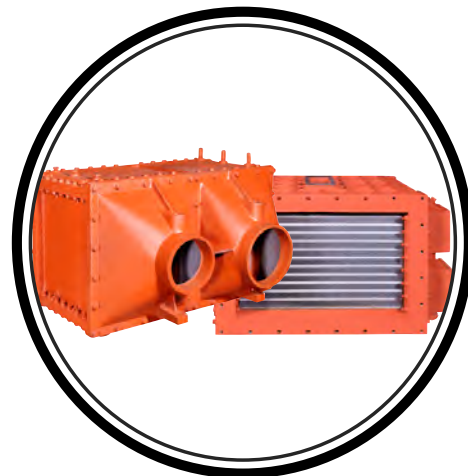

ENGINE PARTS

A sizeable inventory of parts for natural gas engines is on hand.

We also carry a large selection of hard parts such as cylinder heads, blocks, and crankshafts. All items are available both new and rebuilt for immediate shipment.

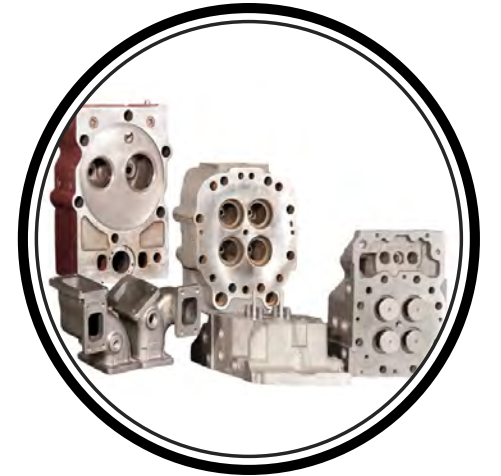

EXHAUST MANIFOLDS

We stock a wide selection of exhaust manifolds and air filters for the most common engines in the industry.

In addition to providing a comprehensive range of repair services, we also provide these units on an exchange or consignment basis.

All repairs on SUPERIOR™ models adhere to engineer certified procedures, with great care taken to consider the application and longevity of the unit.

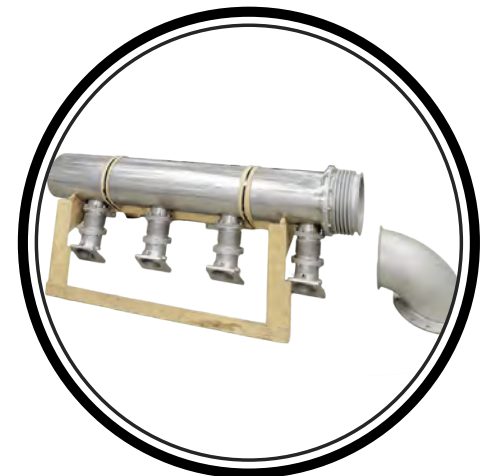

EXPANSION JOINTS

We design, manufacture, and stock a wide variety of premium quality expansion joints. With many of the units in our inventory designed in-house, these units are engineered to be vastly superior to existing O.E.M. models.

A proper seal to the exhaust drive of the turbocharger improves the efficiency of the unit and saves money. Our prices are competitive and if we sell you a unit, we will keep stock in our inventory.



GASKET & MOUNTING KITS

Alamo can meet your needs for air intake connectors and rubber bellows for most of the common heavy duty engines. This is often an overlooked item and we urge our customers to utilize them to minimize maintenance costs.

Air to the turbocharger is 100% unfiltered, therefore a leaking connector can suck in dirt and damage your turbocharger. Every cubic inch of air lost costs you money and a leaking connector can be a safety concern.



WATER JUMPERS

In keeping with our tradition of product development, we improved the design for the water jumper on the SUPERIOR™ 825 line of engines.

These updated units are a bolt-on replacement and will eliminate the safety and environmental problems of glycol leaks due to leaking gaskets and cracked castings. Our updated water jumpers have been extensively field tested to compensate for the misalignment and movement which occurs between the cylinder block and cylinder heads.

Each water jumper kit includes:

- | | |
|------------------|-------------------------|
| 2 Main Bodies | 2 Mating Flange Gaskets |
| 1 Connector Tube | 1 Mounting Fastener Kit |
| 2 O-Rings | |



MORE PRODUCTS

Not finding what you are looking for here?
Call us, toll free. 1-800-988-7260

Combined with access to our global supply network and in-house machining and welding division, we are able to fabricate custom applications and source obscure parts.

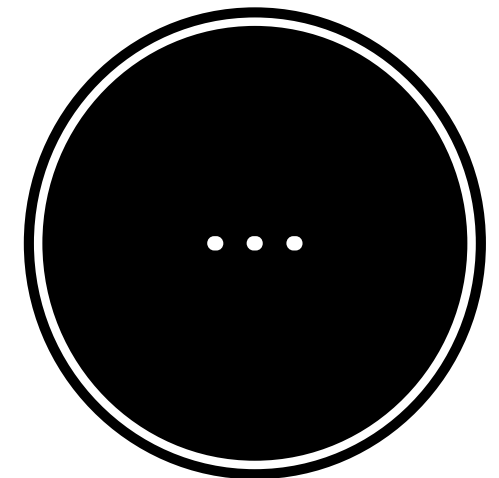

COMPRESSOR COMPONENT REPAIR

In continuing our commitment to providing a full range of service for our customers, we have expanded our portfolio to include compressor component repair, supply, and troubleshooting.

Our team of certified tradesmen have over three decades of experience in the compressor industry, and are committed to maintaining the same standard of quality and service that Alamo has established in the turbocharger industry.

Before reconditioning services are performed, the component pieces are assessed by our resident lead machinists and millwrights. The pieces are then restored in-house for optimal performance, using the following equipment:

- AMC precision boring machine
- Custom built lapping machine
- Custom built piston rod torque bench
- Cylindrical grinder
- Metalizing system
- Non-destructive testing equipment
- Sunnen honing equipment
- Two hydraulic presses
- Three mills
- Five engine lathes

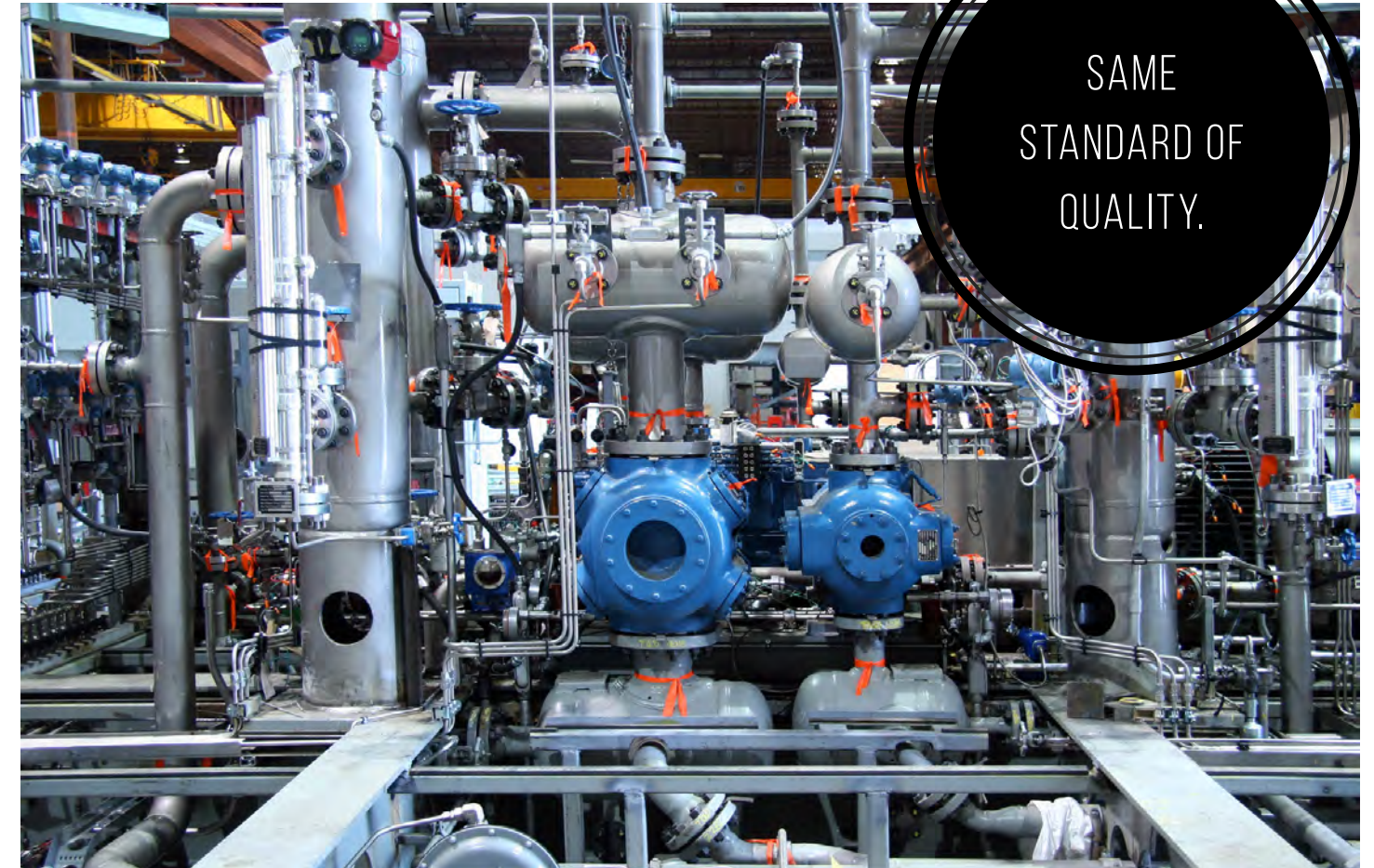

SAME
STANDARD OF
QUALITY.

FULL
RANGE
SERVICE.

RECONDITIONING SERVICES

Packing cases, wiper & auxiliary boxes, compressor valves, piston & rod assemblies, VVCP assemblies, crossheads, connecting rods, and bushings.

FIELD SERVICES

Vibration analysis, custom design, scheduled maintenance, troubleshooting, and inspection.

24 HOUR SERVICE

Due to the maturity of the oil and gas industry, discontinued and obsolete equipment is routinely used in the field. At Alamo we understand that “downtime” costs are critical to daily operation, and requires immediate access to technical support. With this in mind, we have a team dedicated to our industrial customers 24 hours a day to get your equipment back online.

In addition to having our representatives on call, we routinely make field calls and hot shots for our customers in need of emergency assistance.



EXCHANGE PROGRAM

Alamo has developed an extensive supply and exchange program, which allows for quick turnaround and less downtime. Our technicians are factory trained in warranty analysis, enabling us to diagnose the unit in-house the day it arrives in our shop without having to send it to a factory.

Our complete units are available on a cost of repair basis, complete with installation gaskets and shipped in secure containers.



FACTORY OVERHAUL

We understand that buying new isn't an option for all of our customers. At Alamo we are OEM certified to provide overhaul services to many turbocharger models, with repairs often completed in a next-day time frame.

In order to repair almost any item ourselves rather than having to search for new parts, we remanufacture using an IRD soft bearing balancer, a state of the art Schenck HM20BU hard-bearing balancer, and an array of Kent CNC mills and lathes.



PICK-UP & DELIVERY

We have a fully trained crew of employees and a fleet of trucks capable of transporting all types of industrial turbochargers. All fleet vehicles over 4500 kg are enrolled in the Commercial Vehicle Inspection Program. Our field representatives have travelled to gas plants and service stations across North America, and are well versed in on-site delivery practices. All shop personnel have been trained in W.H.I.M.I.S., H2S, Emergency First Aid, and meet industry safety standards.

Our pick-up and delivery feature is a value added option, exclusively offered to our industrial customers in an effort to extend the best standard in service.



ONLINE LISTING

Our website includes a complete listing of parts for OEM brands BorgWarner, Garrett, and Holset.

Each item includes turbine housing options, technical specifications, catalogue downloads and a product comparison feature.



alamoturboschargers.com



QUALITY CONTROL

We have developed a comprehensive quality control program tailored to the variety of turbochargers we work on. If any unit fails to meet the standards set by the program, it is rejected and sent back for requalification.

In addition to inspecting all new parts from our manufacturers, each unit that we overhaul is subjected to a variety of procedures. These include a visual inspection, pressure checking, and a vibration test to ensure integral parts are within specification rating.



WELDING & MACHINING

Alamo perfected the welding and repair of non-ferrous material such as stainless steel and inconel, being one of only a few companies in Alberta still able to perform cast iron welding and fabrication. Experience and procedures developed over many years have allowed us to refine the welding and repair of turbine blades.

Our fully equipped welding division is backed by Alberta Journeymen certification, with full training in all processes of welding including TIG, GMAW, and SMAW. This gives us the ability to custom weld and fabricate any application, whether this involves piping, intercoolers, repairs, or welding on accessories for fittings – we can help you achieve the perfect end result.



MORE SERVICES

Not seeing a service you are looking for?
Call us, toll-free. 1-800-988-7260

In the event that our range of service doesn't match your needs, we will always try to refer you to one of our trusted vendors.

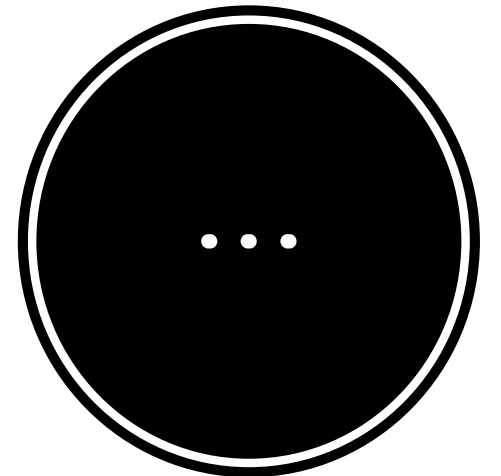

**INDUSTRIAL
HIGH PERFORMANCE
MARINE AND
AGRICULTURAL**